

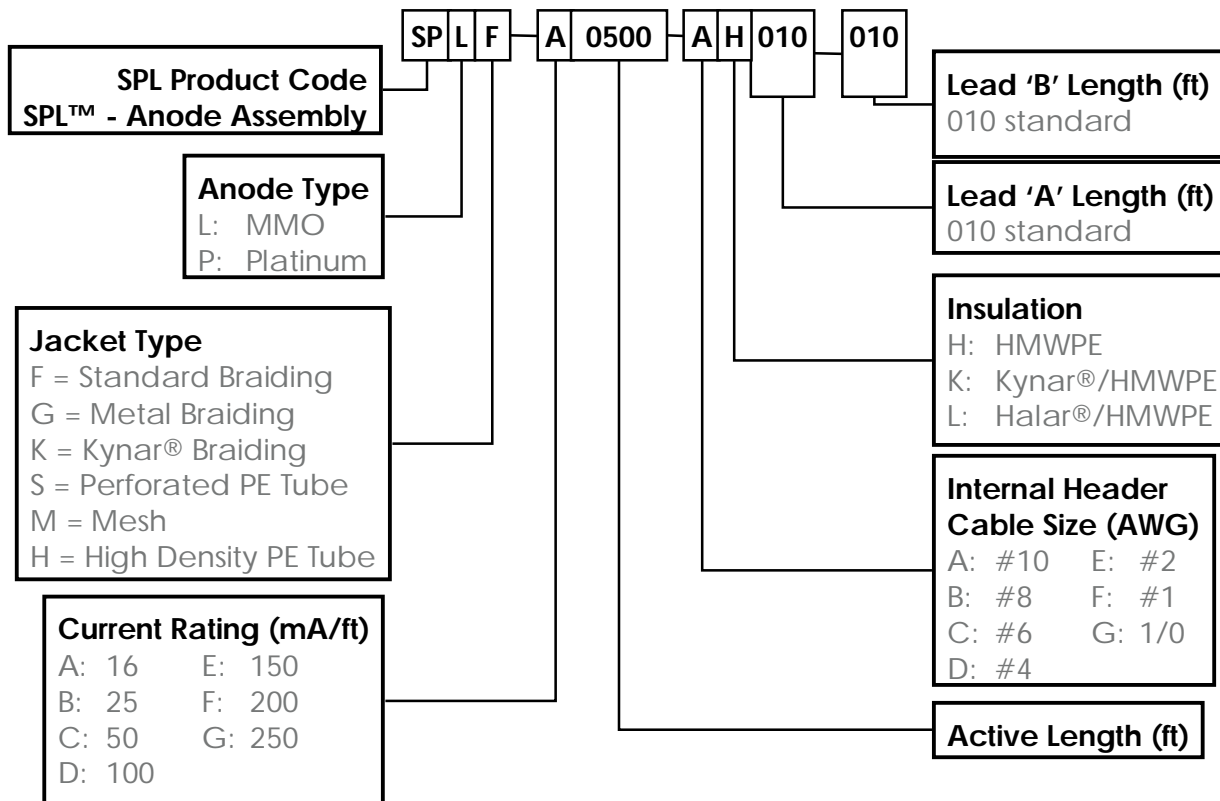

No stronger name in corrosion protection

2009 SPL PRODUCTS PART NUMBER FORMAT

STANDARD SPL CONFIGURATIONS



Example of How to Order SPL™-Anode:

To order 500 ft. of SPL™-Anode with the following specifications:

- Standard braiding
- Current output of 16 milliamperes per linear foot
- Mixed metal oxide as the primary anode
- 10 ft. of #10 AWG, HMWPE leads on both ends

The order code would be as follows: Ex: SPLF-A0500-AH010-010

