



Cathodic Protection Power Plant Challenges



Quick Overview of MATCOR

MATCOR Offerings

Complete Cathodic Protection Service and Product Provider



Construction Services

- ✘ Large fleet of vertical drill rigs
- ✘ Two HDD rigs for tanks and ground bed installations
- ✘ Truck mounted auger for shallow ground bed installations
- ✘ Hydrovac equipment
- ✘ Trenching and other construction services

Engineering and Technical Services

- ✘ AMPP Certified engineers and field technicians for field inspections, troubleshooting, diagnostics, annual inspections and detailed design engineering
- ✘ AC Interference full-service solution provider

Material Supplier

- ✘ World class manufacturing operations located in Chalfont PA and Stafford TX
- ✘ Distributor for many CP related products
- ✘ Warehouse locations in TX, LA, OK, WY and PA



Cathodic Protection and AC Mitigation Experts

What is Cathodic Protection

What is Cathodic Protection?

Cathodic Protection

Cathodic Protection is a means to prevent corrosion of metals (generally carbon steel) through the application of an electrical DC current and stopping the corrosion reaction.

When properly applied, Cathodic Protection stops the corrosion reaction from occurring.

Inorganic Chemistry 201

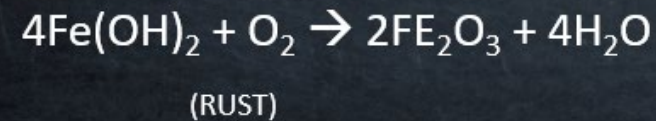
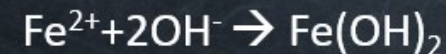

What is Cathodic Protection?

The Corrosion Reaction

- With few exceptions, metals must be refined and processed from their natural state into a usable material

Energy is put into the metal...

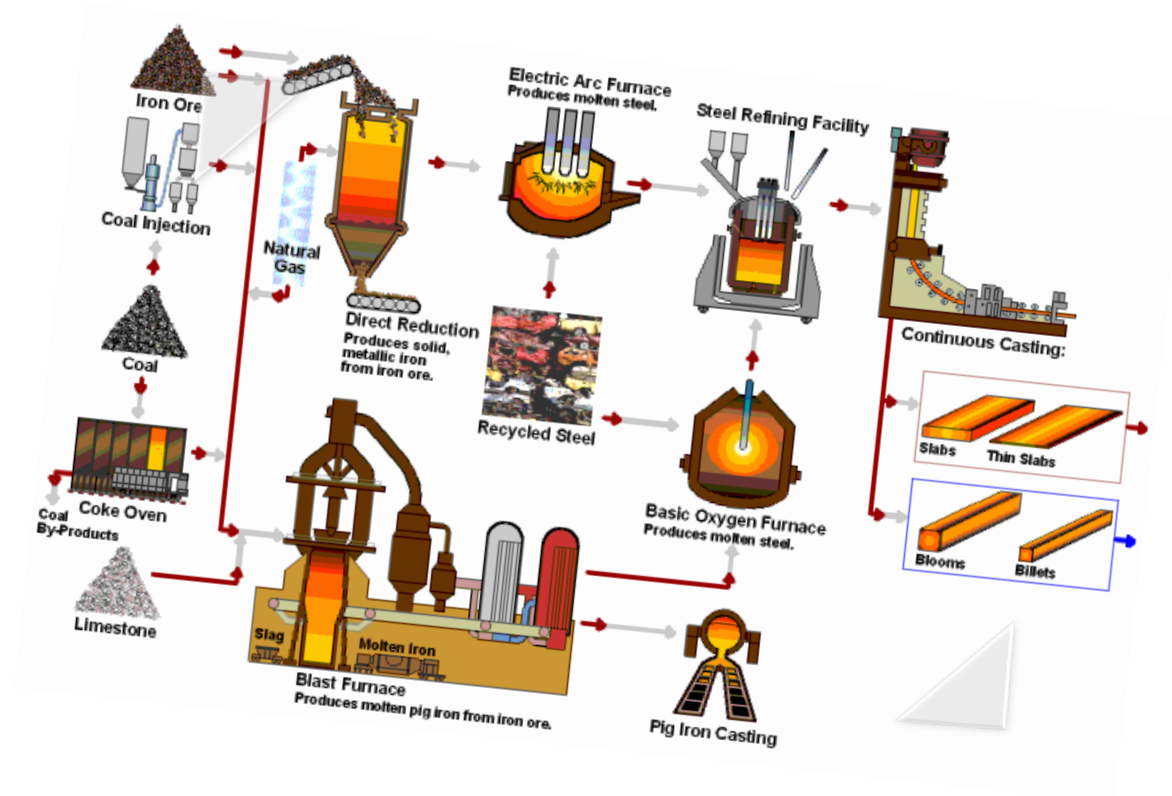

Cathodic Protection creates a protective shield...



With Cathodic Protection

Without Cathodic Protection

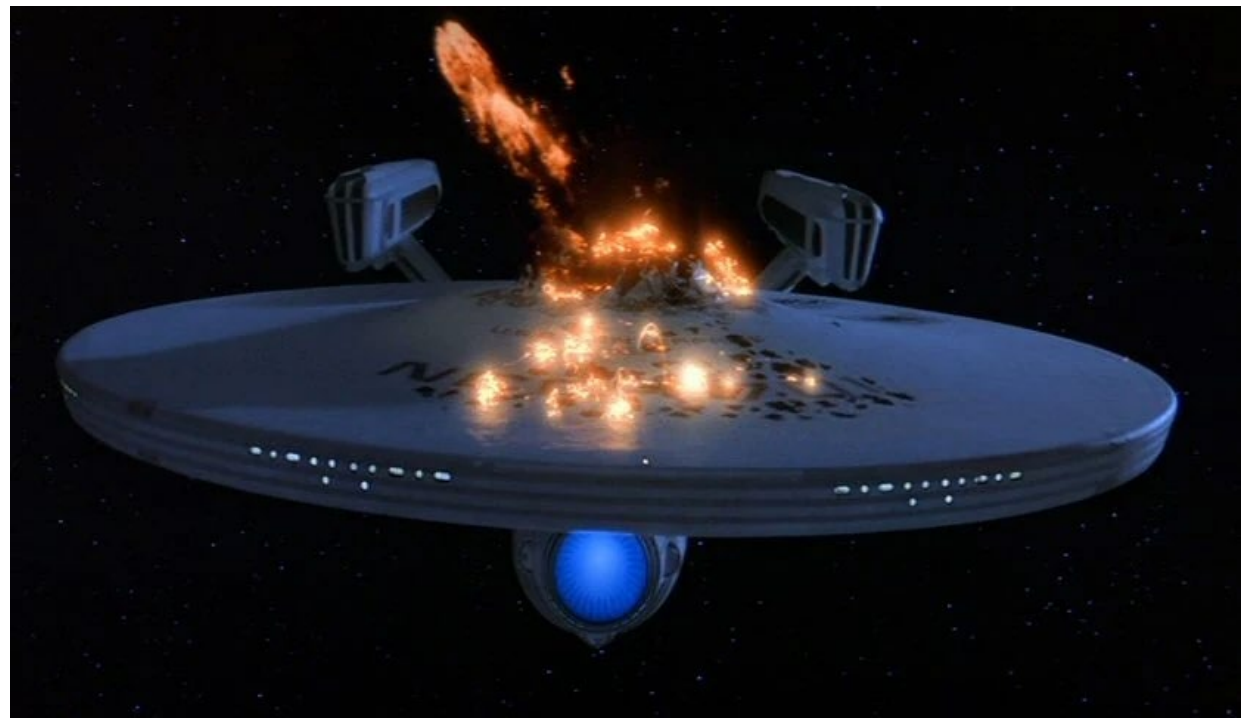



Regulations

Regulated Pipeline Market – Oil and Gas

X Hazardous Materials Pipelines subject to strict PHMSA Regulations

- Cathodic Protection mandated for steel transmission pipelines and tanks associated with pipelines (CFR 49 Part 192 for Gas Pipelines and CFR 49 Part 195 for Liquids Pipelines)
- Must be installed, maintained and tested on a regular basis and owners are subject to audits, fines and consent decrees for failure to comply
- PHMSA's jurisdiction stops at the plant's metering station – inside fence, same gas pipeline but no longer within the purview of DOT.



Good Engineering Practice (not regulated)

✘ Pipelines and other structures still subject to "Good Engineering Practices"

- While not mandated for water pipelines, plants and terminals, cathodic protection system are a common design feature for the past 40+ years.
- Typically applied to "critical service" pipelines including gas, fuel oil, and various water service (potable, circulating, condensate, fire water, etc...)
- Often these systems are installed during plant construction but are not tested regularly and plant maintenance is not qualified maintain these systems

Legal Definition of Good Engineering Practices

Good Engineering Practices means, in respect of any undertaking in any circumstances, the exercise of that degree of care, foresight, prudence and skill that would reasonably and ordinarily be expected from a competent, skilled and experienced person in the same type of undertaking in the same or similar circumstances - *-lawinsider.com*

Contractor Grade CP

Dirty little secret –EPCs provide the bare minimum to check off this box

Contractor Grade CP System

*Utilizes **isolating flanges** to isolate piping from grounding system – lose isolation and system does not work and depletes quickly.*

*Magnesium anodes with minimal, if any, test stations to confirm proper performance. These are “**install and forget**” systems.*

The plant may or may not receive a CP system test report as part of the EPC turnover package.

Isolation can easily be lost and difficult to restore



Owner’s lack of knowledge

*Most power plant maintenance and operations teams have **little understanding** of what CP systems they might have installed.*

*They **lack the training and equipment to properly test and troubleshoot** a cathodic protection system.*

*The operation, or lack thereof, of the CP system is **not critical to the operation of the Power Plant** – at least in the short term. **If the CP system stops working properly there are no alarm bells or warnings and the plant chugs along blissfully ignorant***



Anode Configurations

Anode Configurations

Remote Ground Beds

High powered anodes located remotely deliver large amounts of current over a wide area similar to lighting used at sports stadiums



Anode Configurations

Discrete Anodes

Discrete anodes designs distribute the anodes around the structure trying to assure thorough current distribution similar to lighting around a house.



Anode Configurations

Linear Anodes

Linear anodes designs distribute low powered continuous anodes in close proximity to the structure to assure thorough current distribution similar to fiber optic lighting





Anode Types

Galvanic Anodes

Advantages

No need for power

Often lower cost

Little or no
maintenance

Disadvantages

Low output

“Goldilocks” anodes

Short anode life

No “Power” switch

Beware copper ground
systems

Harder to test

Mag Anodes

- › **Current output depends on soil resistivity**
- › **Consumption rate varies widely**
17.5 lbs/amp.yr
- › **Quality / Consistency issues**
- › **Service Life rated in AmpHr**
Typical 32 lb mag is good for about
1800-2000 AmpHr service
(22mA for 10-year life)



MMO Anodes

- › Introduced in the late 1990s
- › Dimensionally Stable
- › Low cost
- › Long life
- › Low weight
- › Extremely robust



MATCOR is MMO

What is MMO?

*An acid insoluble, crystalline, anhydrous, electrically conductive, dimensionally stable, **electrocatalytic** coating on a titanium base.*

Quality control is very important

NACE TM-108 only applicable standard

CATALYST

noun / cat • a • lyst

Definition of Catalyst

a substance that causes or accelerates a chemical reaction without itself being affected

Impressed Cathodic Protection System (Volume Switch)

Rectifier

- Wide Range of Configurations:
 - Air Cooled / Oil Cooled
 - Pole / Pedestal Mount
 - Single Phase / Three Phase
 - Carbon Steel / Stainless Steel
 - Constant Current / Voltage
 - Auto-Potential Control
 - Monitoring Options



Junction Boxes
Custom bond
and junction
boxes available.



Oil-Immersed Rectifiers
Lifting eyes, lockable,
hinged top and fins for
cooling and strength.



Other Components of a Cathodic Protection System

Other Components





Transmission Piping

Different Types of Piping

› Welded Steel Pipe

- › No concerns with continuity
- › Easy to apply CP

› Ductile and Cast-Iron Pipe

- › Continuity is a big issue
- › More difficult to apply CP

› Pre-Stressed Concrete Cylinder Pipe

- › Continuity an issue
- › Overprotection can damage pipe

Ductile and Cast-Iron Pipe

Electrical continuity of joints is a major concern
PE Encapsulation – helps but not perfect

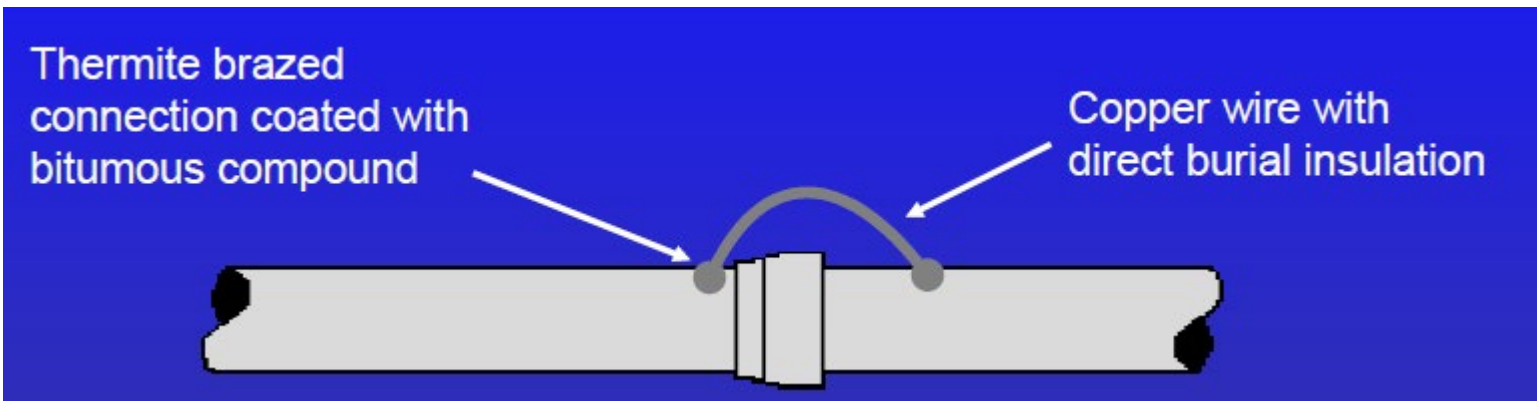
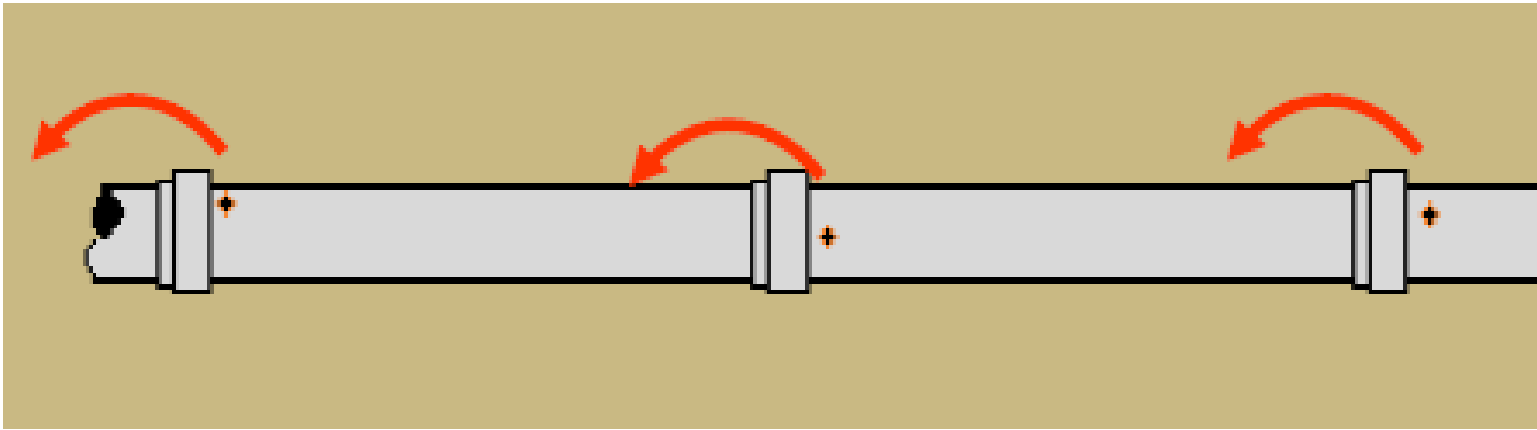

Pre-stressed Concrete Pipe

If stressing wires fail the pipe loses mechanical integrity and can fail catastrophically.

To much CP can cause hydrogen embrittlement of stressing wires leading to failure





Buried Plant Piping Systems

Ohms Law

$$V = I \times R$$



Georg Ohm

As a schoolteacher, Ohm began his research with the new electrochemical cell, invented by Italian scientist Alessandro Volta.

Voltage (V) = Driving force

Current (I) = The flow of electrons

Resistance (R) = Think friction

For our purposes we want to rearrange this equation to $I = V/R$

Challenges for Congested Plant Environments

› Grounding Systems

Plant earthing networks (typically copper in the US) are designed to readily discharge current.

Copper has a much lower natural potential than steel AND it takes a 20 times more current to shift its potential.

Grounding networks are designed for very low resistance to earth.



When piping systems are connected to a grounding grid, the grounding grid pulls large amounts of current away from the intended target.

Isolation

- › Isolation is a strategy that can be used to eliminate the impact of copper grounding on buried piping – required for galvanic anodes to work.
- › Simple piping systems are easy to isolate.
- › Complex piping networks are very difficult to isolate



With proper isolation...

The galvanic anodes are only connected to the piping being protected.

The galvanic anodes have a potential of -1.8V nominally.

The piping has a potential of -0.55V

As electrons bombard the surface of the piping the piping becomes more negative. Once you get to -0.85V you are cathodically protected

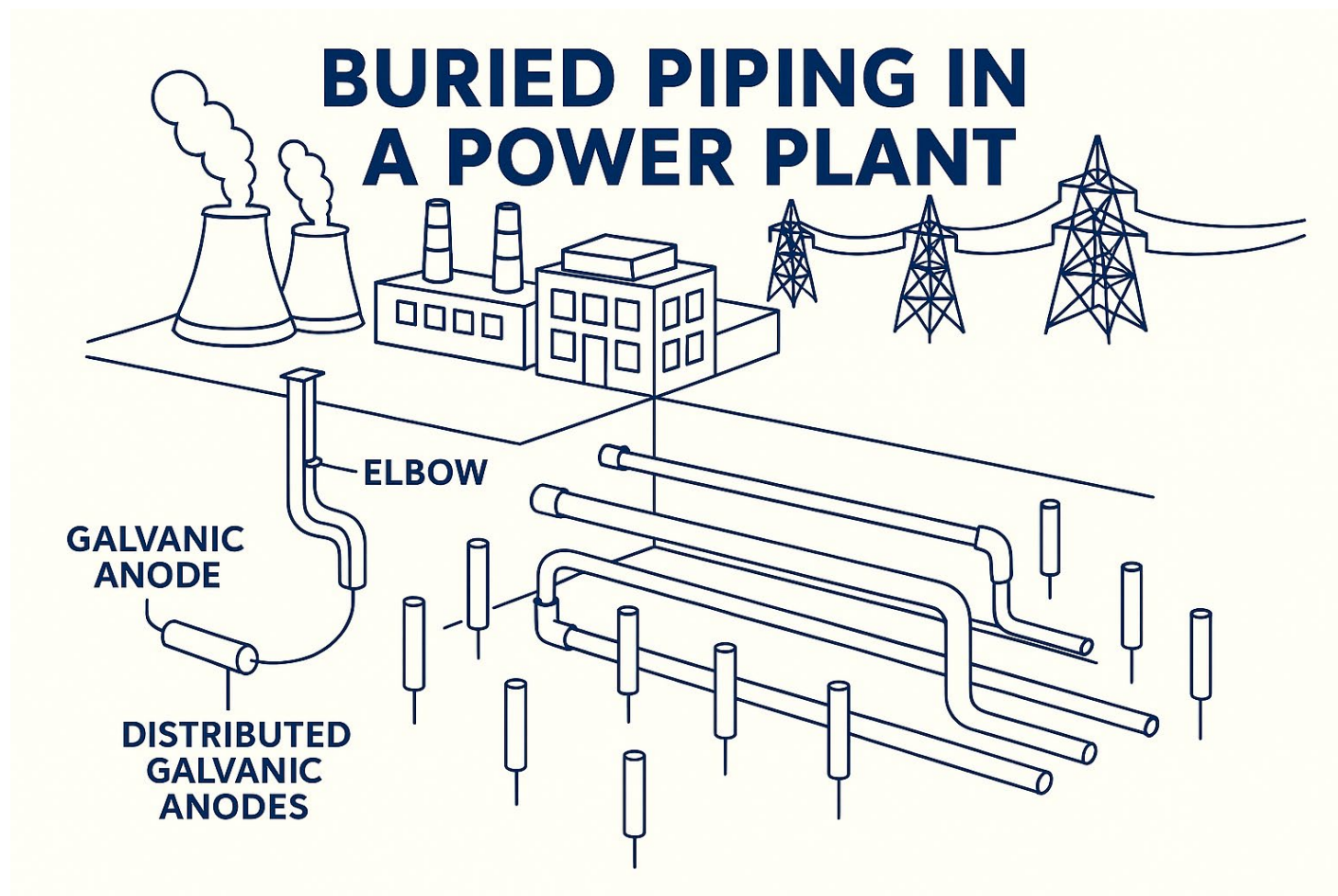

Lose isolation...

The galvanic anodes are now connected to a much larger structure lowers resistance.

The galvanic anodes have a potential of -1.8V nominally.

The piping has a potential of -0.55V
but the copper has a negative potential of -0.2V

The copper will pull all of the current and does not easily polarize.
 (20x more current to polarize)

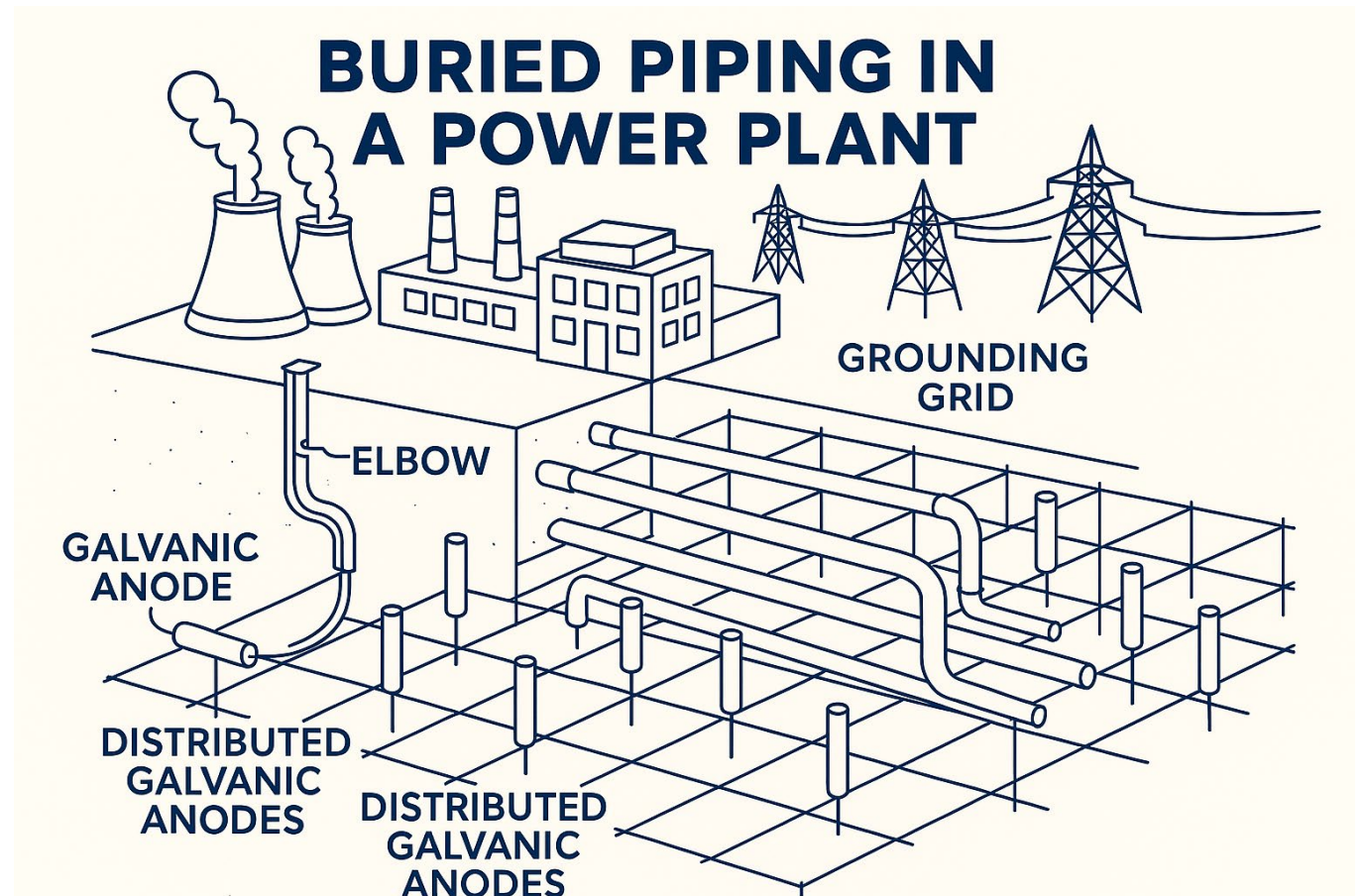

Isolation Flange Kits

- › Used to try and isolate piping from grounding system.

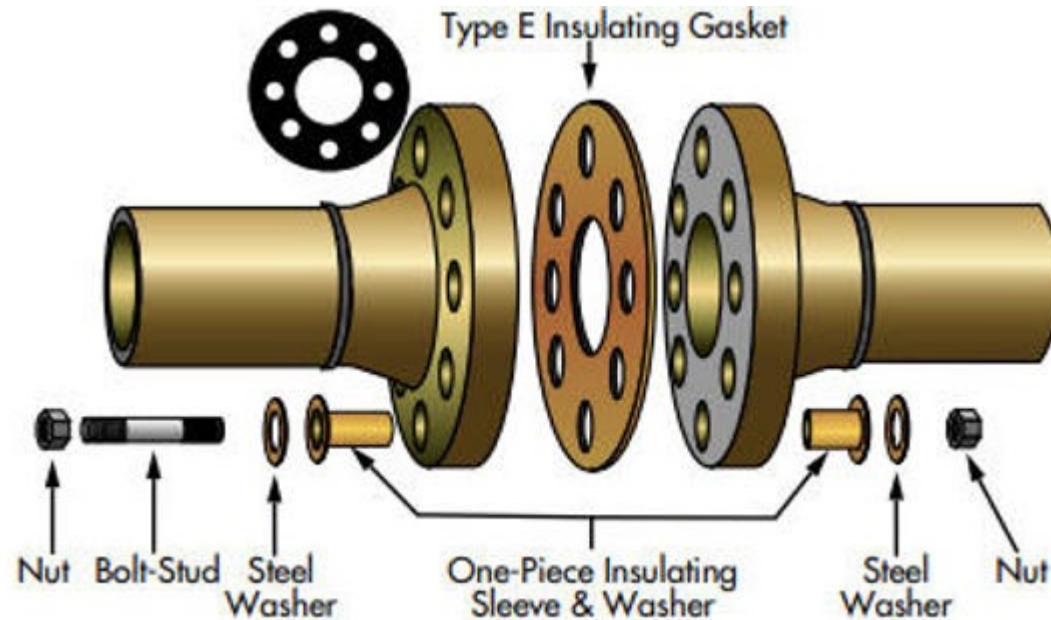

Distributed Anodes

Distributed anodes can be:

Galvanic

Typically, magnesium type

Impressed Current

MMO tubes or canister anodes, High Silicon Cast Iron.



Shallow distributed Anode Systems



- If coverage is not thorough, areas may be unprotected
- Designer must consider grounding grid isolation (critical for galvanic)
- Piping route changes require CP system redesign

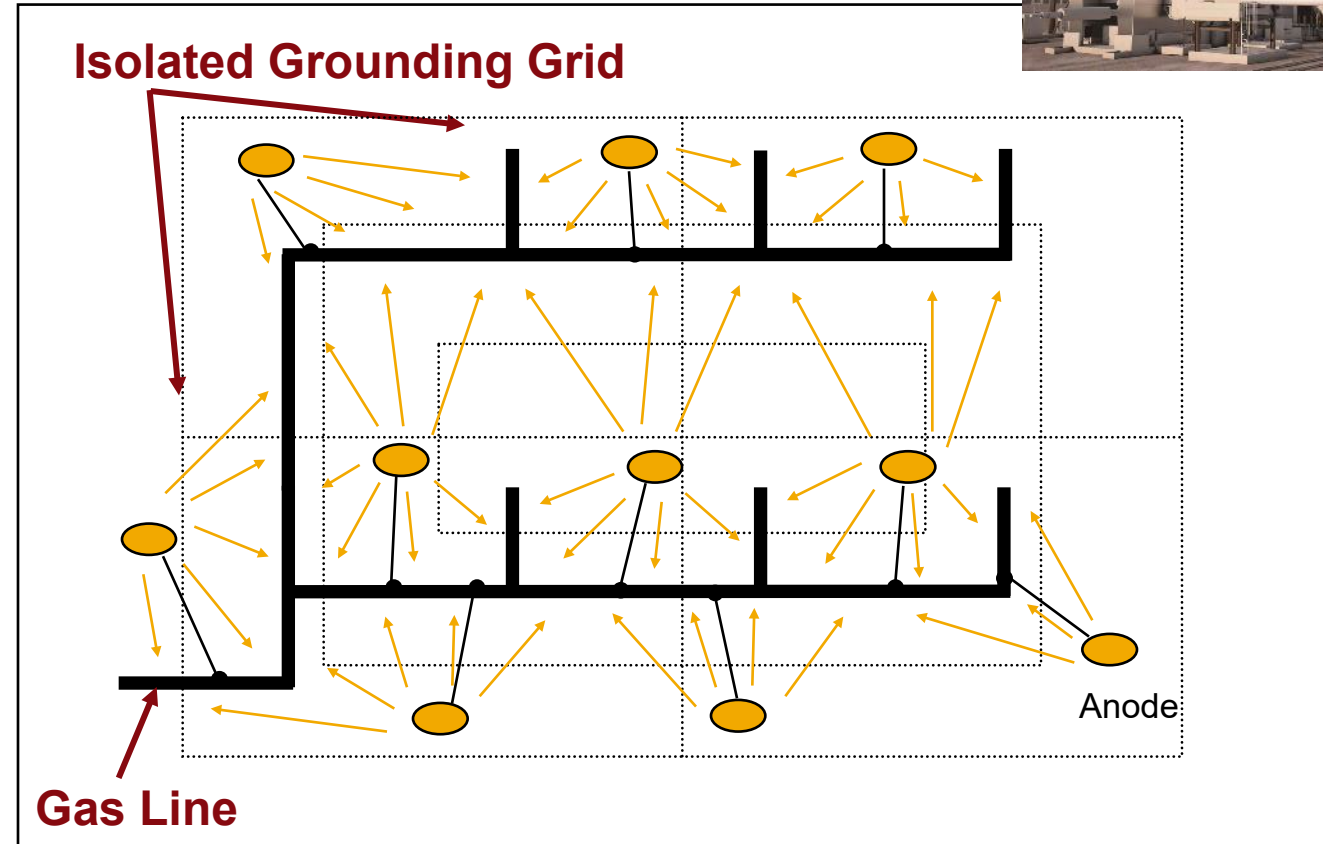

Shallow distributed Anode Systems



- Copper grounding takes current preferentially from intended gas pipeline
- Must raise both copper and steel to -0.85V to be cathodically protected.
- Galvanic anodes increase output while doing nothing to help the pipeline.
- Hamster wheel effect

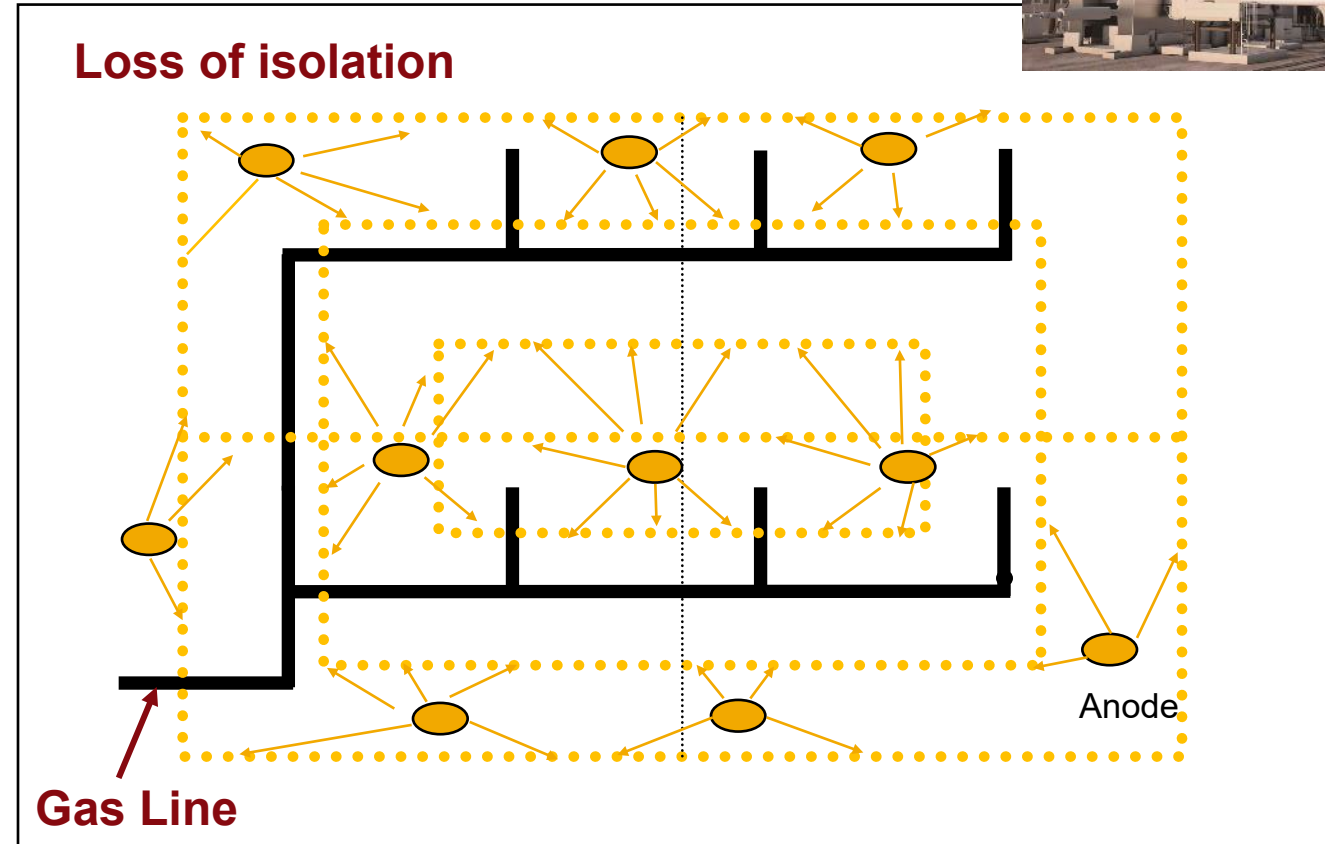

Linear Anodes

Simplified design

Ensures complete coverage

Easy to install

Minimizes stray current and interference issues

Can be sized to have significant losses to grounding system – while still polarizing pipe due to close coupling of anode to structure

Has rectifier to allow for “volume” increase

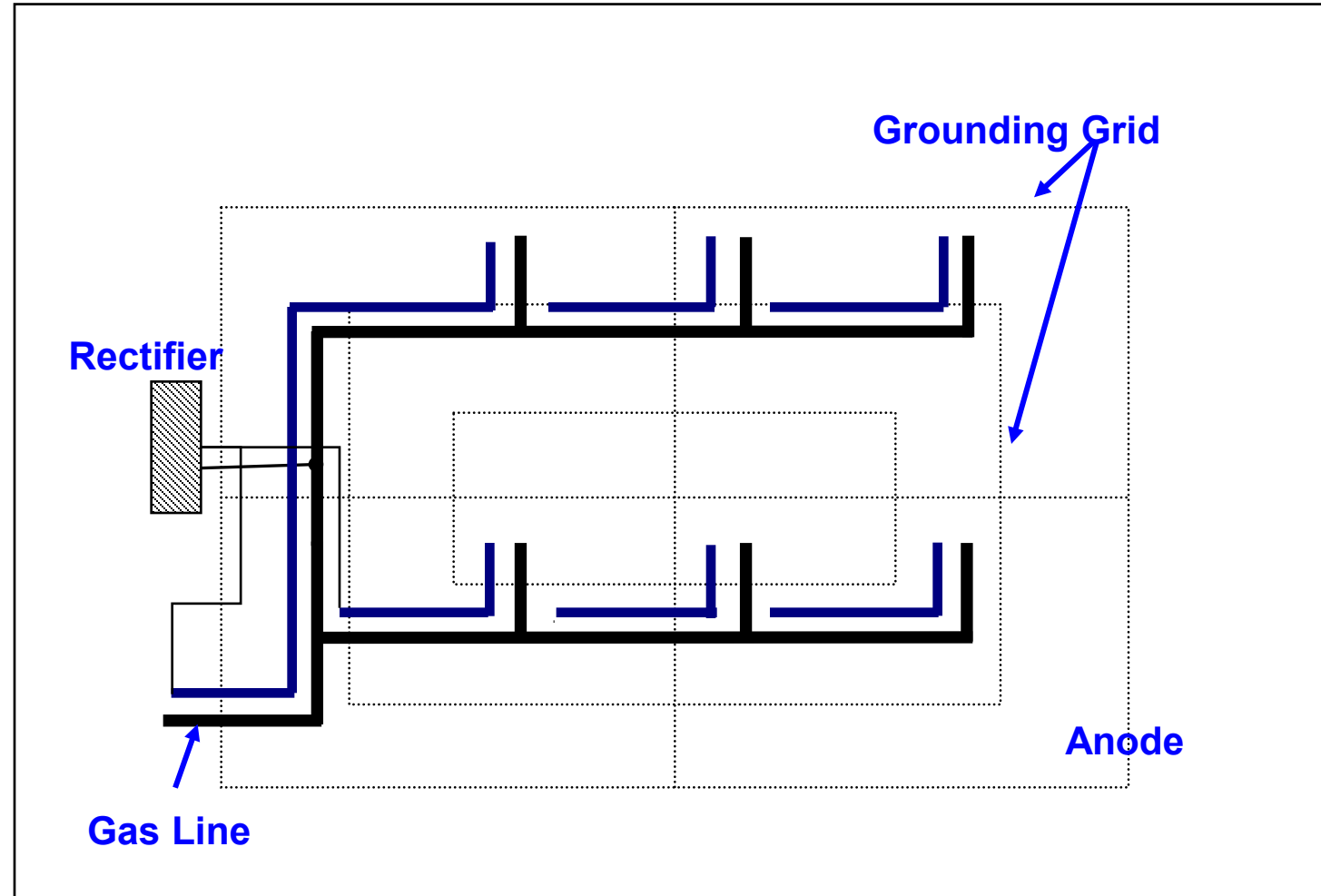

Typical Congested Plant Design

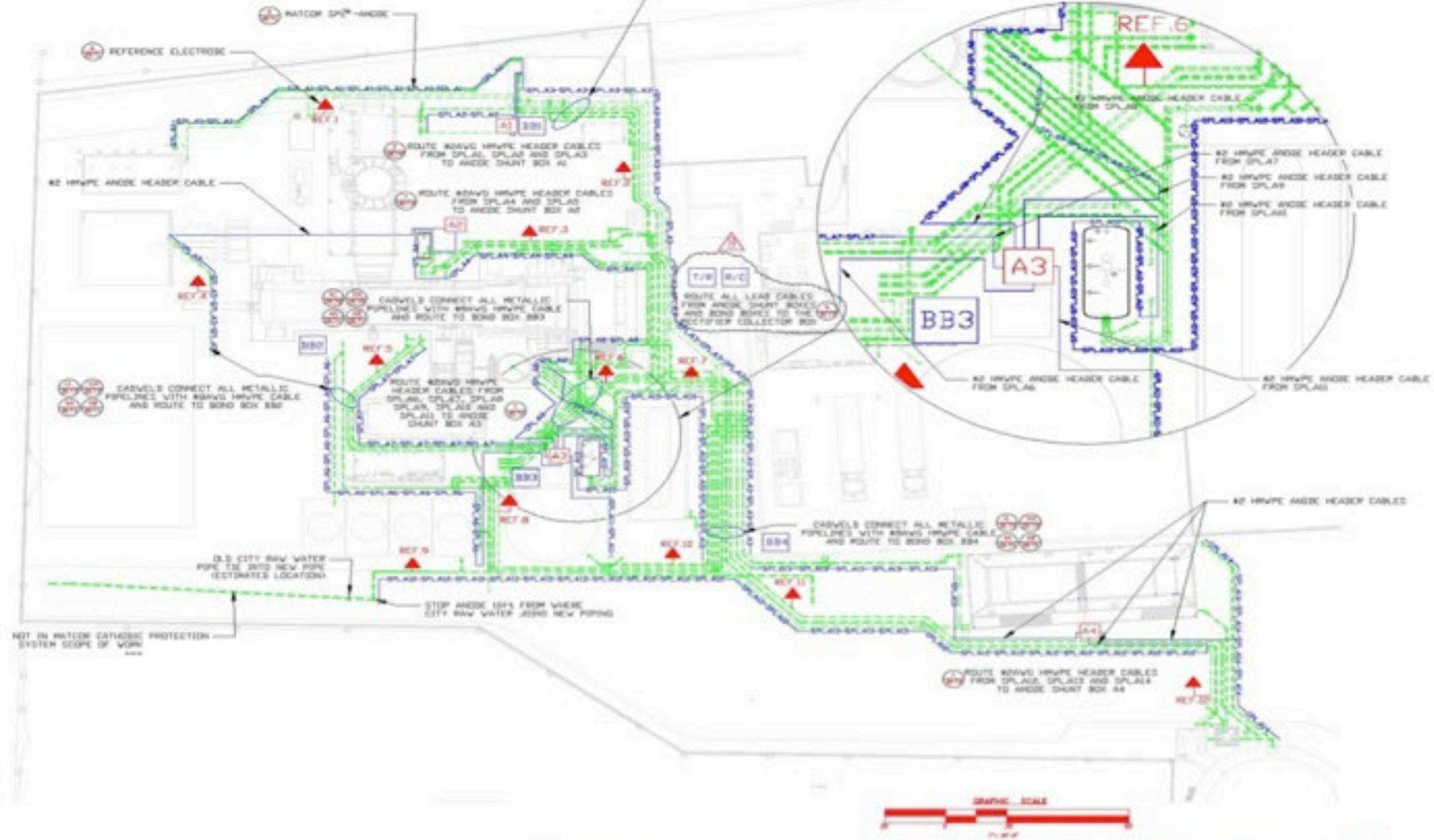

NOTES:

1. ALL PIPING IN COMMON TRENCH WITH SPL ANODE MUST BE BONDED TO ENSURE ELECTRICAL CONTINUITY. SEVERAL BOND BOX'S ARE REQUIRED TO COLLECT PIPE NEGATIVE CONNECTIONS.
2. IT IS THE RESPONSIBILITY OF THE INSTALLATION CONTRACTOR TO ENSURE ALL METALLIC PIPING IN AREAS OF SPL ANODE ARE BONDED INTO THE CATHODIC PROTECTION SYSTEM.
3. LOCATION OF REFERENCE ELECTRODE, ANODE SHUNT, BOND, RECTIFIER COLLECTOR AND TRANSFORMER/RECTIFIER BOXES ARE APPROXIMATE AND CAN BE RELOCATED WITH MATCOR'S APPROVAL.
4. REFERENCE ELECTRODE TO BE INSTALLED 1FT FROM PIPELINE ON THE OPPOSITE OF ANODE WHERE POSSIBLE.
5. TEST STATIONS SHOWN FOR GENERAL PURPOSE ONLY AND CAN BE MOVED TO SUIT.
6. ROUTE SPL ANODE HEADER CABLE AS FOLLOWS:
 ANODE SHUNT BOX A1: CIRCUITS SPLA1, SPLA2 AND SPLA3
 ANODE SHUNT BOX A2: CIRCUITS SPLA4 AND SPLA5
 ANODE SHUNT BOX A3: SPLA6, SPLA7, SPLA8, SPLA9, SPLA10 AND SPLA11
 ANODE SHUNT BOX A4: CIRCUITS SPLA12, SPLA13 AND SPLA14

CP LEGEND

	TRANSFORMER RECTIFIER		BOND BOX
	ANODE SHUNT BOX'S		RECTIFIER COLLECTOR BOX
	REFERENCE ELECTRODES		RECTIFIER COLLECTOR BOX



<p>REVISIONS</p> <table border="1"> <thead> <tr> <th>NO.</th> <th>DATE</th> <th>BY</th> <th>CHK</th> <th>APPN</th> <th>COMMENTS</th> </tr> </thead> <tbody> <tr> <td>1</td> <td>8/12/08</td> <td>WPS</td> <td>WPS</td> <td></td> <td></td> </tr> <tr> <td>2</td> <td>8/12/08</td> <td>WPS</td> <td>WPS</td> <td></td> <td></td> </tr> <tr> <td>REV</td> <td>DATE</td> <td>BY</td> <td>CHK</td> <td>APPN</td> <td>COMMENTS</td> </tr> </tbody> </table>		NO.	DATE	BY	CHK	APPN	COMMENTS	1	8/12/08	WPS	WPS			2	8/12/08	WPS	WPS			REV	DATE	BY	CHK	APPN	COMMENTS	<p>DESIGNER: DWG. SHEET ALL INSTRUMENTS PLANT AND EQUIPMENT TO BE INSTALLED SHALL BE AS SHOWN ON THIS SHEET UNLESS OTHERWISE SPECIFIED IN THE NOTES OR OTHERWISE BY THE CONTRACTOR</p> <p>REVISED ANODE RECTIFIER COLLECTOR BOX METAL ISSUE REVISION DESCRIPTION</p>	<p>PROJECT ENGINEER</p> <p>ENGINEER</p> <p>DATE: 8/12/08 SCALE: 1" = 30'-0" DRAWN: S. J. BROWN</p> <p>CHECKED: [Signature] APPROVED: [Signature]</p>	<p>LILL & DIPAZIO CONSTRUCTORS LLC 711 Sand Run, 2027 Ave., 168 100N, 11109</p> <p>SIGMA ENERGY SOLUTIONS One Huntington Square, Suite 1000 Harrisburg, PA, 17101</p>	<p>ONE CORPORATE CENTER 36 CHAPIN STREET, HARRISBURG, CT 06103</p> <p>MATCOR 301 AIRPORT BLVD DOYLESTOWN PA 18902 (215) 348-2974 WWW.MATCOR.COM</p> <p>R-2081227-CP1</p>
NO.	DATE	BY	CHK	APPN	COMMENTS																								
1	8/12/08	WPS	WPS																										
2	8/12/08	WPS	WPS																										
REV	DATE	BY	CHK	APPN	COMMENTS																								

Typical Congested Plant Design

ALL METALLIC
 W/ HWPE CABLE
 BOND BOX BB1

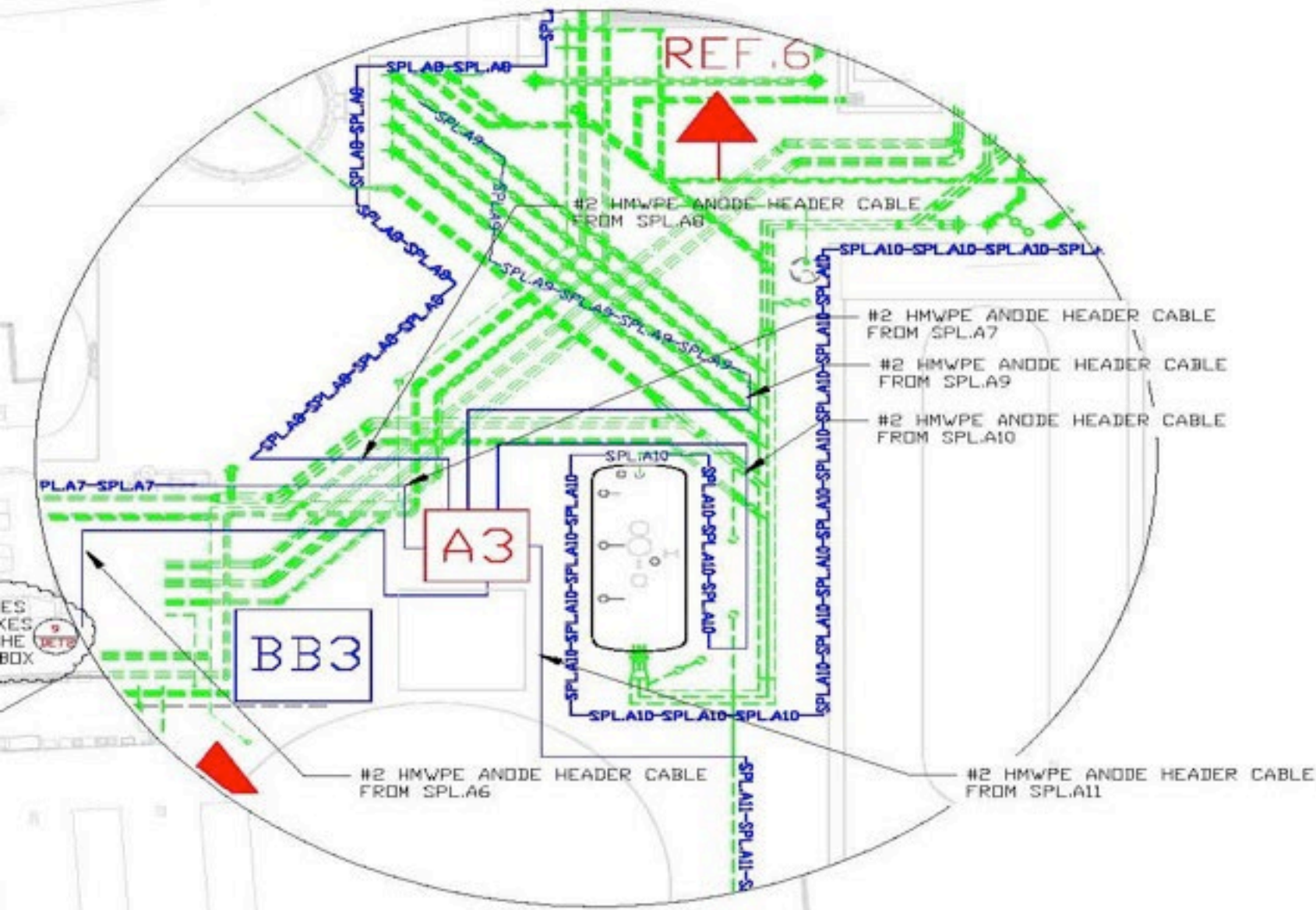
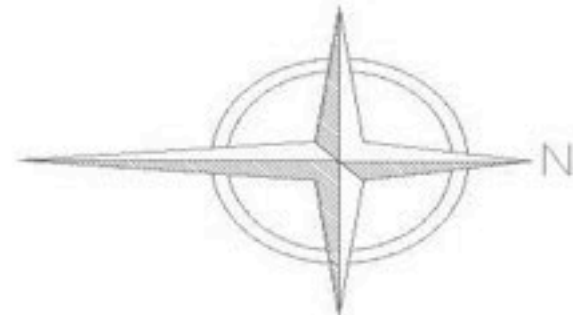

NOTES:

1. ALL PIPING IN COMMON TRENCH WITH SPL ANODE MUST BE BONDED TO ENSURE ELECTRICAL CONTINUITY. SEVERAL BOND BOX'S ARE REQUIRED TO COLLECT PIPE NEGATIVE CONNECTIONS.
2. IT IS THE RESPONSIBILITY OF THE INSTALLATION CONTRACTOR TO ENSURE ALL METALLIC PIPING IN AREAS OF SPL™ ANODE ARE BONDED INTO THE CATHODIC PROTECTION SYSTEM.
3. LOCATION OF REFERENCE ELECTRODE, ANODE SHUNT, BOND, RECTIFIER COLLECTOR AND TRANSFORMER/RECTIFIER BOXES ARE APPROXIMATE AND CAN BE RELOCATED WITH MATCOR'S APPROVAL.
4. REFERENCE ELECTRODE TO BE INSTALLED 1FT FROM PIPELINE ON THE OPPOSITE OF ANODE WHERE POSSIBLE.
5. TEST STATIONS SHOWN FOR GENERAL PURPOSE ONLY AND CAN BE MOVED TO SUIT.
6. ROUTE SPL™-ANODE HEADER CABLE AS FOLLOWS:
 ANODE SHUNT BOX A1: CIRCUITS SPLA1,SPLA2 AND SPLA3
 ANODE SHUNT BOX A2: CIRCUITS SPLA4 AND SPLA5
 ANODE SHUNT BOX A3: SPLA6, SPLA7, SPLA8, SPLA9, SPLA10 AND SPLA11
 ANODE SHUNT BOX A4: CIRCUITS SPLA12, SPLA13 AND SPLA14





Case Story – It won't work

- › New construction power plant in Pennsylvania
- › Being constructed on top of old steel mill site
 - › Being built from grade up
 - › All buildings and equipment on steel piles
 - › Piles had significant corrosion allowance
 - › Isolation not considered practical
 - › Highly congested underground piping systems

Case Story – It won't work

- › Owner's Engineer specified deep well anode system
 - › Required sufficient current capacity to protect all buried structures including:
 - › Pilings
 - › Reinforcing steel in concrete foundations
 - › Copper grounding grid
 - › Buried Piping Systems

Case Story – It won't work

- › Preliminary design calculations yielded in excess of 750 amps to protect all buried metallic structures
- › Would have required a minimum of 15 deep well anodes running at 50 amps each to supply sufficient current
- › Current distribution would have been a nightmare



Case Story – It won't work

- › Confirmed with owner that buried piping was only metallic structure of interest for CP
- › Buried piping CP requirements were calculated at less than 25 amps of current – the balance of the current required was to protect other structures
- › Pilings would shield current from piping system



Case Story – It won't work

- › Convinced owner to try a linear anode system
- › Instead of 15+ rectifiers and 750+ amps, system would be designed with 4 rectifiers and would require less than 50 amps of current with allowance for losses to nearby metallic structures
- › Owner's engineer (not a CP firm) said it would not work and required a waiver of responsibility from the owner

Case Story – It won't work

- › Installed “excessive” number of reference cells to confirm proper system performance during testing
- › Allowed for 100% losses to other structures
- › Used a zoned approach to assure that anode outputs could be controlled in zones – dividing the plant into quadrants
- › Installation was start/stop as piping was installed piecemeal around other plant construction activities

Case Story – It won't work

- › CP system commissioned with minimal problems – only a couple of minor breaks had to be repaired
- › Current losses to other structures was less than 50% of the total current required to meet criteria for buried piping
- › Current distribution was outstanding

Case Story – It won't work

- › 17 years later – CP system is working great and being tested annually.
- › Have had some isolated issues with cabling systems being cut by contractors working at the facility. These are negative cables going back to the Negative Junction Boxes and anode lead cables going back to the Anode Junction boxes.

Case Story – Ignorance is Bliss

- Received a phone call from Power Plant Manager
- Plant was 11 months old – EPC contractor had a 12 mo. Warranty
- Plant Manager could find no record of CP system having been tested
- He wanted to know if it actually was working properly

Case Story

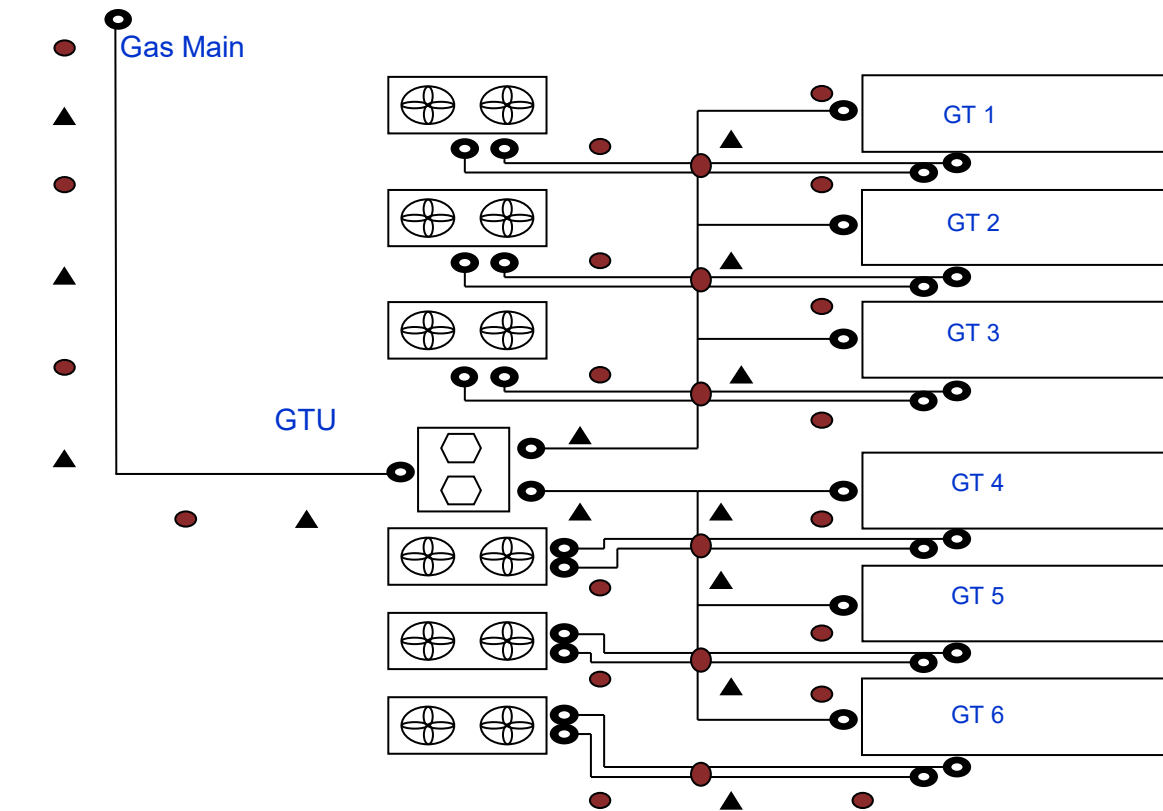

Gas pipeline with distributed bed anode system

Very common design

Cheap and meets specifications

Legend

- Galvanic anode direct connection
- ▲ Galvanic anode with test station
- ◌ Isolation flange
- Continuity bond

Case Story

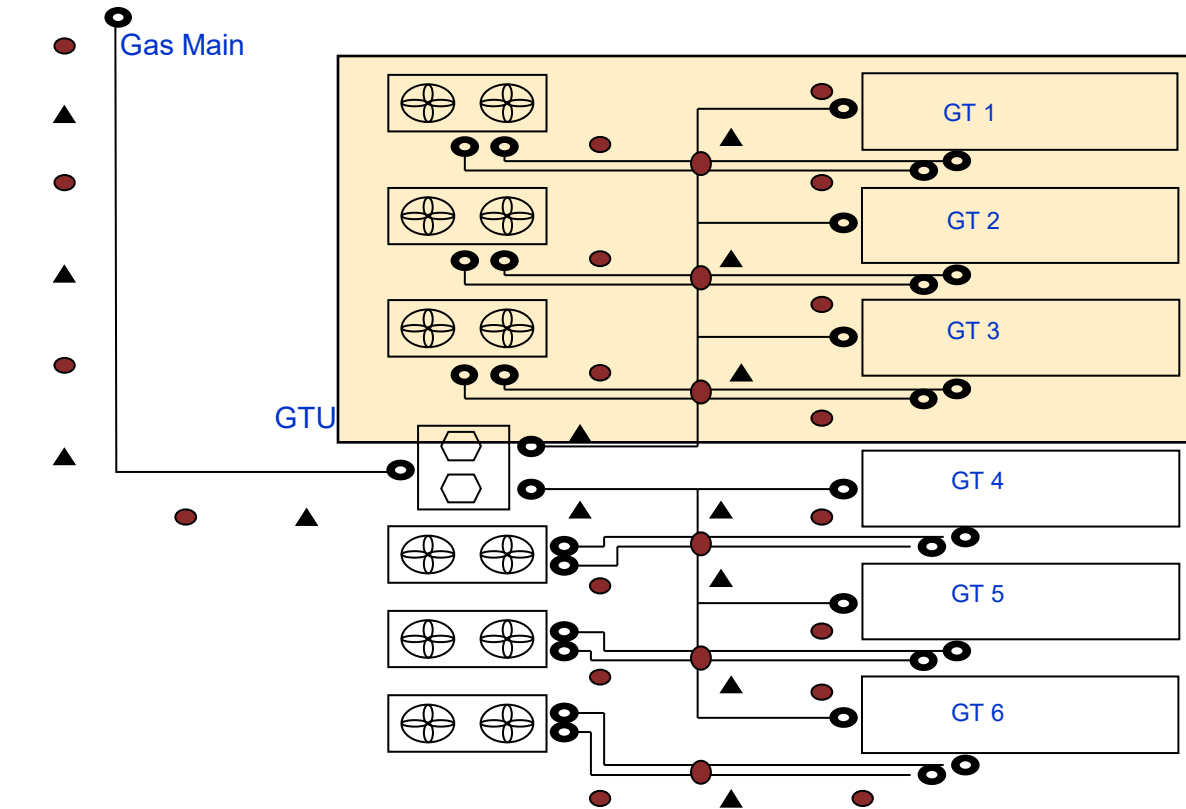

Entire North Side of plant piping was not receiving any CP current

Anodes were running full throttle with no affect on the piping

Legend

- Galvanic anode direct connection
- ▲ Galvanic anode with test station
- ◌ Isolation flange
- Continuity bond

Case Story

- Testing found that almost half of the facility was not under protection
- During testing, the isolation flanges were examined and found to be working properly
- EPC Contractor did not receive his final payment on the project
- Electrical subcontractor had to dig up several spots to find source of loss of isolation.

Case Story

- Lessons learned
 - CP systems relying on isolation must be regularly tested
 - Loss of isolation can be difficult to find even in the simplest of piping systems
 - Lowest installed cost may not be best
 - You get what you inspect
 - Caveat Emptor

Testing Cathodic Protection Systems

Testing



It is important in any plant environment to have a lot of test stations because soil access is difficult, and piping is complex

Testing



Trained personnel can confirm the proper working of the CP system using calibrated voltage meters taking readings at test stations

Testing

The system design should take into consideration access to rectifiers and junction boxes and should allow for troubleshooting of buried anode assemblies and header cabling



Using AMPP Criteria – 100 mV Shift

- › 1. What the 100 mV Shift Criterion Actually Requires
 - › To properly apply the 100 mV criterion, you must be able to measure aAt least 100 mV of true polarization, either:

100 mV negative shift after CP is applied, or
100 mV decay after CP is interrupted
 - › The measurement must represent **true IR-free polarization of the structure**, not voltage drops in soil, concrete, or grounding systems.

Using AMPP Criteria – 100 mV Shift

- › Extensive Grounding Grids Mask True Polarization
Plant areas almost always contain:
 - › Dense copper grounding grids
 - › Multiple parallel metallic paths
 - › Low-resistance current return paths

- › These create:
 - › Large, unstable IR drops
 - › Rapid voltage collapses that look like decay but are not
 - › Erratic potentials unrelated to corrosion risk

This directly violates the fundamental assumption of the 100 mV criterion that the measured voltage change reflects polarization of the steel surface.

What should you use

- › Polarized Instant-Off Potential ≤ -850 mV CSE
Measured at coupons or well-defined test
- › Coupon-Based 100 mV Decay
Preferred where grounding density is high
(not commonly found in plant CP systems but should be considered as an inexpensive means of testing CP effectiveness)
- › Modeling + Localized Measurements
Used in high-value facilities
Combined with inspection data
(think nuclear plant piping systems – modeling can be extremely expensive and this approach requires a lot of inspection data to validate.)

Thank You